

艺辉铸造科技有限公司是 **Yihui Casting® 艺辉** 注册商标的专用权人，  
经艺辉铸造科技有限公司许可授权瑞辉自动化系统（广东）有限公司使用。

Yihui Casting Technology Co., Ltd. hold and reserve exclusive right of **Yihui Casting® 艺辉**

授权方 Authorized Party

### 艺辉铸造科技有限公司

Yihui Casting Technology Co., Ltd.

地址: 广东省广州市番禺区沙头街沙南路50号

Add.: No.50, Shanan Road, Shatou Street, Panyu District, Guangzhou City,  
Guangdong Province, China

电话/ Tel : +86-20-34734999/34734666 传真/Fax: +86-20-84872122

邮箱/Email: info@yihuicasting.com

网址/ Web: www.yihuicasting.com www.yihuicasting.cn

制造商 Agency

### 瑞辉自动化系统(广东)有限公司

Ruihui Auto System (Guangdong) Co. Ltd.

地址: 广东省广州市番禺区沙湾镇福涌牛眠岗工业区一街10号

Add.: No.10, First Street, Niutang Industrial Park, Fuchong, Shawan  
Town, Panyu District, Guangzhou City, Guangdong province, China

# MacLac

## 睿智版真空注蜡机

### MVLOS Vacuum Wax Injector



专注于首饰铸造  
Specializing In Jewelry Casting

专业 敬业 合作 共赢  
profession Dedication Cooperation Double-win

## 五、设备报错代码说明 Equipment error code description

当设备出现错误时,若显示提示“E 1 1 1”字样。其代表意思如下:

- ① 第一个“1”代表蜡缸加压漏气,检查接管,或者上盖是否锁紧。
- ② 第二个“1”代表夹具压动漏气,检查气管是否漏气。
- ③ 第三个“1”代表夹具推动漏气,检查气管是否漏气。

When the device occur error, it displays "E 1 1 1". Its representative problem is as follows:

- ① The first "1" means that the wax chamber is pressurized and leaks. Check whether the connection pipe or the cover is locked or not.
- ② The second "1" means that the clamp compress is leaked. Check whether the air pipe is leaked or not.
- ③ The third "1" means air leakage when the clamp is pushed. Check whether the air pipe is leaked or not.

## 六、包装清单 Packing list

打开包装时,请检查一下配件是否齐全。

When opening the package, please check whether the accessories are complete or not.

配件清单 Parts list			
序号 No.	配件名称 Parts name	数量 Quantity	单位 Unit
1	真空注蜡机Vacuum wax injector	1	台SET
2	IW-6睿智版配件 IW-6 MVLOS accessories	1	盒BOX
3	托模板套装Acrylic Kits	1	盒BOX
4	机械手Clamp	1	台SET
5	真空泵Vacuum pump	1	台SET
6	说明书Manual	1	本PC

#### 4.7 自动/手动模式选择 Automatic/manual mode selection

- 自动模式选择: 将主机红色自动开关至按下状态  
先将胶模放在亚克力工装上, 推进机械手, 亚克力工装到位磁铁触发设备启动;
- 手动模式: 将主机红色自动开关至抬起状态  
先将胶模放在亚克力工装上, 推进机械手, 再按控制面板的启动按钮触发设备启动。

- Auto mode selection: turn the red auto switch of machine to the pressed station  
Put the rubber mold on the acrylic plate, push it into the clamp, the magnet on the acrylic plate triggers the device to start;
- Manual mode: turn the red auto switch of machine to the raised station  
Put the rubber mold on the acrylic plate first, push it into the clamp, and then press the START button on the control panel to trigger the device to start.

#### 4.8 夹具上下调节 Up and down adjustment for auto clamp

- 机械手右下角逆时针拨动转盘, 机械手上升;
  - 机械手右下角顺时针拨动转盘, 机械手下降;
- (注: 通过镜子可观察注蜡嘴与模具口是否对齐, 通过拨动转盘调节合适的高度。)
- Turn the turntable counterclockwise at the lower right side of the clamp to make the clamp rises;
  - Turn the turntable clockwise at the lower right side of the clamp to make clamp down;
- (Note: You can observe whether the injection nozzle is aligned with the mold nozzle through the mirror, and adjust the appropriate height by turning the turntable.)

#### 4.9 压模位置调节 Adjust position of mould

抓住压模气缸逆时针拧松, 移动位置, 顺时针拧紧即可

Hold the cylinder to loosen it counterclockwise, move the position and tighten it clockwise.

## 目录 Catalog

声明 STATEMENT	1
一、设备参数介绍 Equipment parameters introduction	2
注蜡机技术参数 Technical parameters for wax injector	2
机械手技术参数 Technical parameters for auto clamp	3
真空泵技术参数 Technical parameters for vacuum pump	3
二、安装指导 Installation guidance	3
使用条件 Conditions for using	3
注蜡机箱与机械手连接 Connection between the wax injector and auto clamp	4
气管、信号线、电源线连接 Connection of pipe, signal wire and power wire	6
三、操作面板介绍 Operation panel introduction	8
操作面板示意图 Schematic diagram of operation panel	8
操作面板(上) Operation panel (up)	9
操作面板(下) Operation panel (down)	10
四、操作说明 Operating instructions	12
总气压调节 Total air pressure adjustment	12
加蜡步骤 Step for add wax	12
排蜡步骤 Step for exhaust wax	12
工件查看与清零 Workpiece viewing and clearing	13
参数设置 Parameter setting	13
系统参数设置与软件版本查看 System parameter setting and software version viewing	14
自动/手动模式选择 Automatic/manual mode selection	15
夹具上下调节 Up and down adjustment for auto clamp	15
压模位置调节 Adjust position of mould	15
五、设备报错代码说明 Equipment error code description	16
六、包装清单 Packing list	16

## 声明

致用户：

- 感谢您对瑞辉自动化系统(广东)有限公司的信赖和支持,选购艺辉牌系列产品,为安全操作并最大限度发挥本机性能,请在操作前仔细阅读说明书,并严格遵守安全规则,以防发生意外伤害,造成不必要的损失。
- 在机器使用的过程中,如遇到问题可以随时联系本公司销售人员,我们将会竭诚为您服务。
- 在保修期间,如果未经本公司允许,用户不得擅自拆开机器进行错误的检修,如擅自拆开机器,保修期将自动失效,不再享受本公司保修服务。
- 机器使用时所产生损失、利益损失和各种违规操作造成的各种间接损害,概与本公司无关。
- 未经本公司许可,产品说明书的所有内容,不得以任何形式翻版、传播、转载。
- 说明书因修改而进行的变更,恕不另外通知。如果您发现任何错误或遗漏,请向您所购买的供应商反馈,对此,我们深表感谢。

## STATEMENT

To users:

- Thanks for choosing Yihui brand products of Yihui Casting Technology Co., Ltd. We are greatly appreciated for the support and trust you give to us. To ensure safe operation and play the property of this machine in full, please read the user manual in advance and observe the safety rules in case that accidents happen and unnecessary loss occurs.
- If you meet any problem when using this machine, please feel free to contact our salespersons. We will try our best to give you service.
- During the warranty period, user is not allowed to disassemble the machine without prior permission of the manufacturer, if you did so, the warranty would automatically expire and the manufacturer wouldn't be obliged to provide warranty.
- We are not responsible for the loss including loss in interest and all indirect damages caused by operations due to rule-breaking operations.
- Without our permission, it is prohibited to copy, disseminate or reprint the whole content of this user manual in any form.
- This manual is subject to alterations without prior notice. If you find any mistake or omission in this manual, please inform the supplier you bought the machine from. We will be very grateful for this.

版本号:V1.0 2021.04.09

## 4.6 模式设置与软件版本查看

### System parameter setting and software version viewing

①运行模式选择：一键代码/非一键代码。

一键代码：按“设置”按键,设置灯亮,系统进入设置模式,通过上下按键选择P1项,输入数值“1”并按保存按键。

[一键代码说明:有十组一键代码参数,通过数字按键0-9快速选择调用(用户可自由修改,有保存功能)]

非一键代码：按设置按键,设置灯亮,系统进入设置模式,通过上下按键选择P1项,输入参数“0”并按保存按键。

[非一键代码说明:一组参数(用户可自由修改,有保存功能)键值参数显示1-6]

②软件版本查看:按设置按键,设置灯亮,系统进入设置模式,通过上下按键选择P0项,右侧“数值显示窗口”显示程序版本。

③工件数量查看:长按“排气/工件”按键显示工件数量。

① Operation mode selection: One-key code/non-one-key code.

One - key code: Press the "SET" button, the SET light is on, and the system enters the setting mode. Though the up and down buttons to select item P1, input the value "1" and press the SET button to save it.

[One - key code description: There are 10 groups of one-key code parameters, which can be quickly selected and used by the number buttons 0-9 (the user can freely revise, and with save function)]

Non - one - key code: Press the SET button, the SET light is on, and the system enters the setting mode. Though the up and down buttons to select item P1, input the parameter "0" and press the SET button to save it.

[Non - one - key code description: a group of parameter (users can freely modify, with save function) value parameter display 1-6]

②Viewing the software version: press the SET button, the setting light is on, the system enters the setting mode, and the P0 item is selected by the up and down buttons, and the program version is displayed on the right "value display".

③Viewing the number of workpieces: keep press the " Exhaust / Workpiece " button to display the number of workpieces.

#### 4.4 工件清零 Workpiece clearing

长按“排气/工件”按键显示工件数量, 按键不释放, 此时输入“0”, 系统将工件清零。

Press Exhaust / Workpiece till screen show number of workpiece, keep pressing this button and input "0", system will do zero clearing automatically.

#### 4.5 参数设置 Parameter setting

气压单位KPa, 时间单位秒, 输入最大数255

Pressure unit: KPa, time unit: second, input the maximum number 255

- 一次注射压力
- 二次注射压力
- 再次启动时间
- 压模压力
- 压模延时进模压力
- Press 1
- Press 2
- Timing for P.2
- Clamp Pre
- Forward Pre

举例说明: 设置一键代码值0的一次注射压力70KPa、二次注射压力80KPa、再次启动时间0.5S、压模压力90KPa、压模延时5S, 进模压力100KPa。

Example: Set the one-key code value 0, the press 1 is 70KPa, the Press 2 is 80KPa, the Timing for P.2 is 0.5S, the Clamp Pre. is 90KPa, the Hold time is 5S, and the Forward Pre. is 100KPa.

- ① 择一键代码“0”
- ② 进入设置模式: 按下“设置”按键, 灯亮进入设置模式。
- ③ 选择功能按键: 按下“一次注射压力”, 此时右侧数值显卡值调动, 输入“70”并按确定按键, 数值不闪烁代表数值保存完成。
- ④ 选择功能按键: 按下“二次注射压力”, 此时右侧数值显卡值调动, 输入“80”并按确定按键, 数值不闪烁代表数值保存完成。
- ⑤ 选择功能按键: 按下“再次启动时间”, 此时右侧数值显卡值调动, 输入“5”并按确定按键, 数值不闪烁代表数值保存完成。
- ⑥ 依次类推完成所有操作, 再次按“设置”按键, 灯灭, 退出设置模式。

- ① Choose number "0".
- ② Enter the setting mode: press the "SET" button, the light is on to enter the setting mode.
- ③ Select the function button: Press "Press 1", and the value of the number display on the right side will be adjusted at this time. input "70" and press the Enter button. If the value does not flash, indicating that the value is saved.
- ④ Select the function button: Press "Press 2", and the value of the number display on the right is adjusted. Input "80" and press the Enter button. If the value does not flash, indicating that the value is saved.
- ⑤ Select the function button: press "Timing for P.2", the value of the right-side number display will be adjusted at this time, input "5" and press the Enter button, if the value does not flash, indicating that the value is saved.
- ⑥ Complete all operations as above process, press the "SET" button again, the light is off, and exit the setting mode.

## 一、设备参数介绍 Equipment parameter introduction

### 1. 注蜡机技术参数 Technical parameters for wax injector

- 电源: 单相AC 220V±10% 50 / 60Hz
- 功率: 500W
- 保险丝规格: 5A/250V
- 蜡缸加热温度范围: 55-85°C(±1°C)
- 蜡嘴加热温度范围: 55-85°C(±1°C)
- 真空定时范围: 0-12S(±0.1s)
- 注蜡定时范围: 0-12S(±0.1s)
- 蜡缸容量: 3Kg
- 外部气压: 0.4-0.7MPa
- 调压阀设定气压: 0.4MPa
- 第一次注射压力: 出厂限制200KPa
- 第二次注射压力: 出厂限制200KPa
- 再次启动时间: 建议小于0.5 S, 不需要二次加压, 设置为0
- 夹具压模气压: 小于256KPa
- 夹具推模气压: 小于256KPa
- 压模延时: 小于256S
- 最大工件数: 999999
- 存储参数组: 一键模式 10组 +非一键模式1组
- 外型尺寸: L527×W294×D506(mm)
- 机箱重量: 21kg
- 整机包装箱尺寸: L 615 × W515 × D560(mm)
- 整机包装箱重量: 42kg
- Power supply: single-phase AC 220V±10% 50/60Hz
- Power: 500W
- Fuse specification: 5A/250V
- Temperature range for wax chamber: 55-85°C(±1°C)
- Temperature range for wax nozzle: 55-85°C(±1°C)
- Vacuum timing range: 0-12S(±0.1s)
- Timing range for injection: 0-12S(±0.1s)
- Capacity of wax chamber: 3Kg
- External air pressure: 0.4-0.7MPa
- Setting pressure: 0.4MPa
- First injection pressure (1): ≤200KPa
- Second injection pressure(2): ≤ 200KPa
- Restart time: advice ≤ 0.5S, no require second pressure, set 0
- Compress pressure: ≤ 256KPa
- Forward pressure: ≤ 256KPa
- Compression delay: ≤ 256S
- Max number of workpieces: 999999
- Parameters storage: 10 groups, one-key operation
- Machine dimensions: L527×W294×D506(mm)
- Net weight: 21kg
- Package size: L615×W515×D560(mm)
- Package weight: 42kg

## 2.机械手技术参数 Technical parameters for auto clamp

- 标准夹具最大胶模尺寸: L135 × W105 × D45(mm)
- 加宽型大夹具胶模尺寸: L135 × W135 × D60(mm)
- Standard size for rubber mould:L135 × W105 × D45(mm)
- Extra size for rubber mould:L135 × W135 × D60(mm)

## 4.真空泵技术参数 Technical parameters for vacuum pump

- 电源: AC 220V±10% 50 / 60Hz
- 功率: 120W
- 最大真空压力: -100KPa
- 抽气速率: 1.2L/S
- 加油量: 160mL
- Voltage: AC 220V±10% 50 / 60Hz
- Power: 120W
- Maximum vacuum pressure: -100KPa
- Pumping rate: 1.2L/S
- Oil storage: 160mL

## 二、安装指导 Installation guide

### 1.使用条件 Conditions for using

- 电压 AC220V ±10%;
- 使用开关必须带漏电保护的空气开关, 电源供电必须接地;
- 压缩空气必须进行干燥、除尘、除油处理并且压力稳定;
- 设备周围不能放置易燃易爆物品;
- 不能在有粉尘有害气体环境下使用此机器。
- Voltage AC220V ±10%;
- The switch must be the air switch with leakage protection, and the power supply must be grounded;
- The compressed air must be dried , dust-removed, and oil-removed treatment and the pressure should be stable;
- Don' t place flammable and explosive materials around the equipment;
- Don' t use this machine in an environment with dust and harmful gases.

## 四、操作说明 Operating instructions

### 4.1 总气压调节 Total air pressure adjustment

调压阀位于控制箱右侧, 拔起后调节, 建议值400Kpa。

The pressure regulating valve is located on the right side of the control box, adjust it after pulling up, the recommended value is 400Kpa.

### 4.2 加蜡步骤 Step for add wax

- ①按下排蜡按键, 设备自动停止对真空室抽真空(蜡缸与真空室互通);
- ②选择功能“第一次注射压力”, 进入设置模式, 再按“排气”按键, 出现“OUT---”字样, 等待压力值为0;
- ③打开上盖, 添加蜡;
- ④盖好上盖;
- ⑤按“设置”按键, 按键灯灭, 退出排气模式;
- ⑥取消排蜡按键对蜡缸抽真空。

- ①Press the Exhaust button, and the equipment will automatically stop vacuum (the wax chamber and the vacuum chamber is connecting each other);
- ②Select the function " Press 1 " to enter the setting mode, and then press the " Exhaust " button and appear "OUT---", and wait for the pressure to be 0;
- ③Open the cover and add wax;
- ④Close the cover;
- ⑤Press the "SET" button, the button light is off, and exit the exhaust mode;
- ⑥Exit the Exhaust button to vacuum the wax chamber.

### 4.3 排蜡步骤 Step for exhaust wax

每天注蜡工作结束需要进行排蜡。

- ①设置好熔炼室压力为50KPa, 按下排蜡开关, 此时真空室压力等于蜡缸压力。
- ②将接蜡盒放置排蜡口下方(注意眼睛请勿水平直视排蜡口, 以免蜡排放伤害)缓慢打开侧面的排蜡阀门, 将真空室的蜡向外排。

Xhaust wax is required after finish working at the end of every day .

- ①Set the pressure of the melting chamber to 50KPa and press the wax discharge switch. At this time, the pressure of the vacuum chamber is equal to the pressure of the wax chamber.
- ②Place the wax box under the Exhaust port (be careful not to look directly at the Exhaust port horizontally to avoid exhaust damage) open the wax exhaust valve slowly on the side to exhaust wax .

### 3.2 按键功能介绍

- ①功能按键：一次注射压力、二次注射压力、再次启动时间、压模压力、压模延时，进模压力；
- ②启动按键：启动注蜡；
- ③设置按键：灯亮进入设置模式，再按灯灭退出设置模式；
- ④保存按键：修改参数，数值闪动，按下保存按键，数值停止调动，参数保存；
- ⑤排气/工件按键：(排气功能：按下设置灯亮后按排气/工件查看功能：长按时显示工件数量)；
- ⑥上下按键：菜单翻页查看；
- ⑦0-9数字按键：在设置功能可以进行参数输入，在非设置时可一键代码选择代码号(注蜡程序过程，按键无效)。

### 3.2 Introduction for buttons' functions

- ①Function buttons: Press 1, Press 2, Timing for P. 2, Clamp Pre., Hold time, Forward Pre.;
- ②START button: start injecting;
- ③SET button: the light is on to enter the setting mode, and then the light is off is to exit the setting mode;
- ④Enter button: revise the parameters, the value flashes, press the Enter button, the value stops transferring, keep the parameters;
- ⑤Exhaust / Workpiece button: (Exhaust function: press the SET, the light is on, and then press it to exhaust/Workpiece viewing function: display the number of workpieces when long pressing);
- ⑥Up and down buttons: turn the page to view the menu;
- ⑦0-9 number buttons: parameters can be input in the setting function, and the code number can be selected by one key when it is not set (the wax injection procedure is in progress, the key is invalid).

## 2.注蜡机箱与机械手连接 Connection between the wax injector and auto clamp

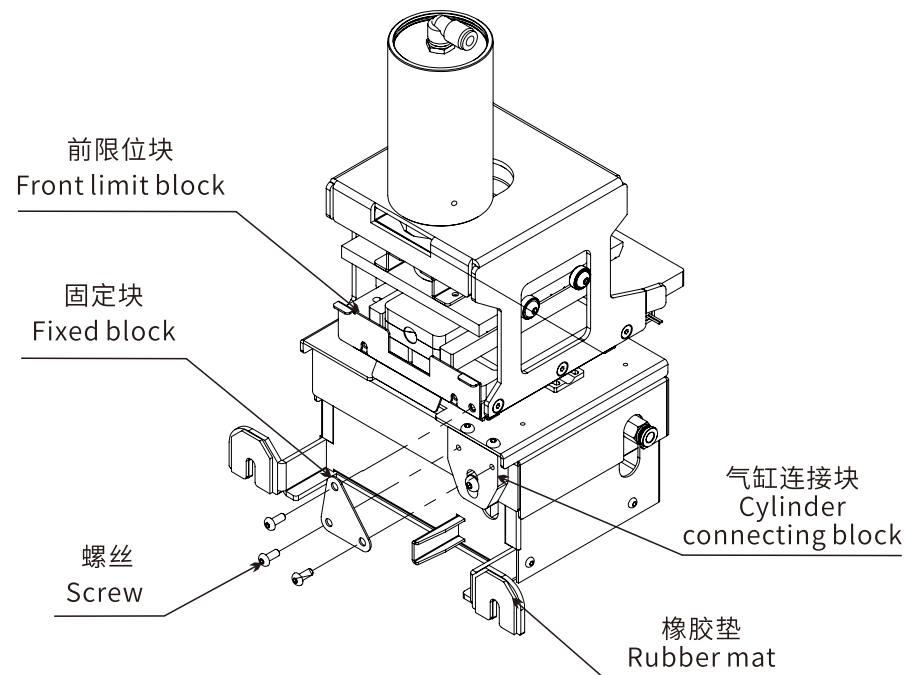

拆卸运输专用“固定块”示意图  
Schematic diagram for disassembling "fixed block"

- ①卸下“固定块”的3颗螺丝，将“固定块”保存好。(如需要打包运输时，将“固定板”固定回原位，防止机械手在运输过程中因摆动造成的二次损坏)；
- ②将“注蜡主机”平放在工作台面上；
- ③将注蜡主机上的两个“胶头螺丝”旋转松动，旋转出一定的距离；
- ④将“机械手”挂靠在注蜡主机的两个“胶头螺丝”上将“胶头螺丝”拧紧；
- ⑤转动机械手底部的“调节螺丝”，使“机械手”水平放置；
- ⑥将“接蜡杯”放置于“机械手”相应的卡位上，完成安装。

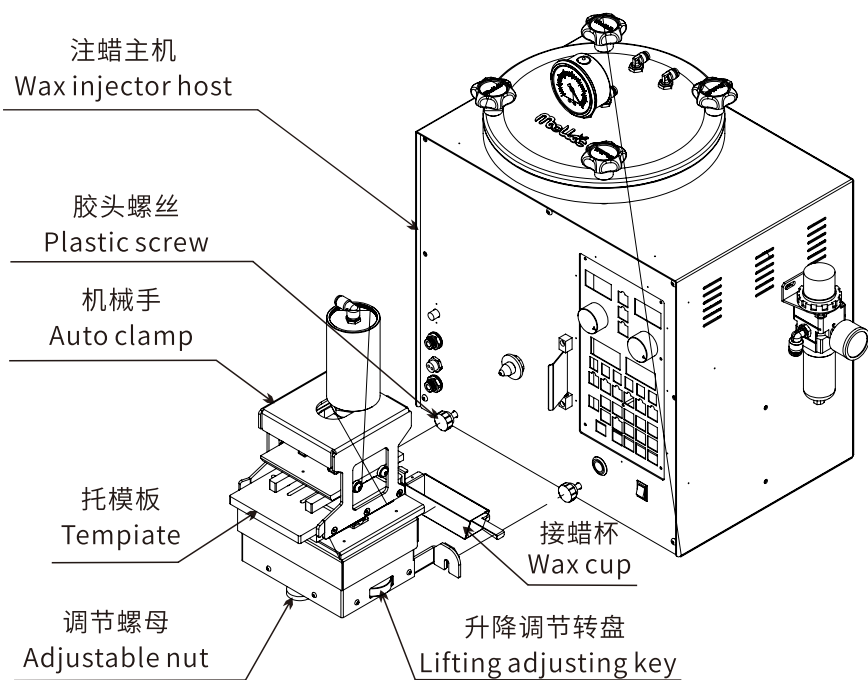

注蜡机箱与机械手连接示意图  
Schematic diagram for connection  
between the wax injector and clamp

- ❶ Remove the 3 screws of the "fixed block" and save the "fixed block". (If you need to pack and transport , fix the " fixed plate " back to the original position to prevent secondary damage caused by the swing of the manipulator during transportation) ;
- ❷ Place the "wax injection host" on the working table ;
- ❸ Rotate the two "plastic screw" on the wax injection host to a certain distance ;
- ❹ Hold the " auto clamp" on the two "plastic screws" of the wax injection host and tight the " plastic screw" ;
- ❺ Turn the "Adjustment nut" at the bottom of the auto clamp to place the "auto clamp" horizontally ;
- ❻ Place the " wax cup" on the corresponding card position of the "auto clamp" to complete the installation.

## 2.4 编码旋钮说明

- ❶ 按下切换温度与时间, 超过5秒未动作, 需要按一次进行唤醒;
- ❷ 左侧编码旋转调节蜡缸温度与真空时间, 右侧编码旋钮调节蜡嘴温度与注入时间。

## 2.4 Description of coding knob

- ❶ Press the switch for temperature and time. if there is no action for more than 5 seconds, you need to press it once again to set;
- ❷ The encoder on the left is to adjust the wax chamber temperature and vacuum time , and the encoder on the right is to adjust the wax nozzle temperature and injection time.

## 3.操作面板(下) Operation panel (down)

### 3.1 显示介绍

- ❶ 两组四位数值显示: 第1个功能按键的数值显示在左侧窗口, 第2个功能按键的数值显示在右侧窗口;
- ❷ 6个单数值显示窗口: 一键代码模式显示代码值, 非一键模式显示123456, 当再次启动时候和压模延时参数设置值大于0时, 该窗口有代码显示, 提示已经开启此功能;
- ❸ 6个功能指示灯: 功能显示;
- ❹ 设置指示灯: 灯亮代表进入设置状态。

### 3.1 Display introduction

- ❶ Two - group of four-digit number display: the value of the first function button is displayed in the left window , and the value of the second function button is displayed in the right window;
- ❷ 6 single - value display windows: one-key code mode displays the code value, non-one-key mode displays 123456, when restarting and the compression mold delay parameter setting value is greater than 0, the window has a code display, prompting that this function has been turned on ;
- ❸ 6 function indicators: function display;
- ❹ Setting indicators: when the light is on, it means entering the setting state.



## 2.操作面板(上) Operation panel (up)

### 2.1 温度选择按键及指示灯

灯亮:显示窗口数据为温度显示

(当按下温度按键时,灯亮:左窗口显示值为蜡缸温度,右窗口显示值为蜡嘴温度)

### 2.2 时间选择按键及指示灯

灯亮:显示窗口数据为时间显示

(当按下时间按键时,灯亮:左窗口显示值为真空时间,右窗口显示值为注蜡时间)

### 2.1 Temperature selection button and indicator

Light on: display window data is for temperature display

(When the temperature button is pressed, the light is on: the value displayed in the left window is the temperature of the wax chamber, and the value displayed in the right window is the temperature of the wax nozzle)

### 2.2 Time selection button and indicator

Light on: display window data is for time display

(When the time button is pressed, the light is on: the value displayed in the left window is the vacuum time, and the value displayed in the right window is the wax injection time)

### 2.3 终止切换按键及指示灯

灯亮:禁止主机抽真空与注蜡

灯灭:允许主机抽真空与注蜡

- 当数字显示窗口显示末位为“.”时,表示正在加热(如73.3.),若末位不显示“.”,则表示加热结束(如77.7)。
- 当数字显示窗口显示“LL.L”时,则表示当前温度比设置温度低,低温提示。
- 当数字显示窗口显示“HH.H”时,则表示当前温度比设置温度高,超温提示。

### 2.3 Stop the switch button and indicator.

Light on: Forbid vacuum pumping and injection.

Light off: Allow the wax injector to vacuum pumping and injection

- When the last digit of the digital display is ".", it means heating ( as 73.3.), if the last digit doesn't display ".", it means finish the heating(such as 77.7).
- When the digital display shows "LL.L", it means that the current temperature is lower than the setting temperature, the low-temperature hint.
- When the digital display shows "HH.H", it means that the current temperature is higher than the setting temperature, and the over-temperature hint.

## 3.气管、信号线、电源线的连接 Connection of pipe, signal wire and power wire

注蜡机箱前面气管、信号电缆连线示意图

Schematic diagram for the pipe and signal wire connection on the front of the wax injector

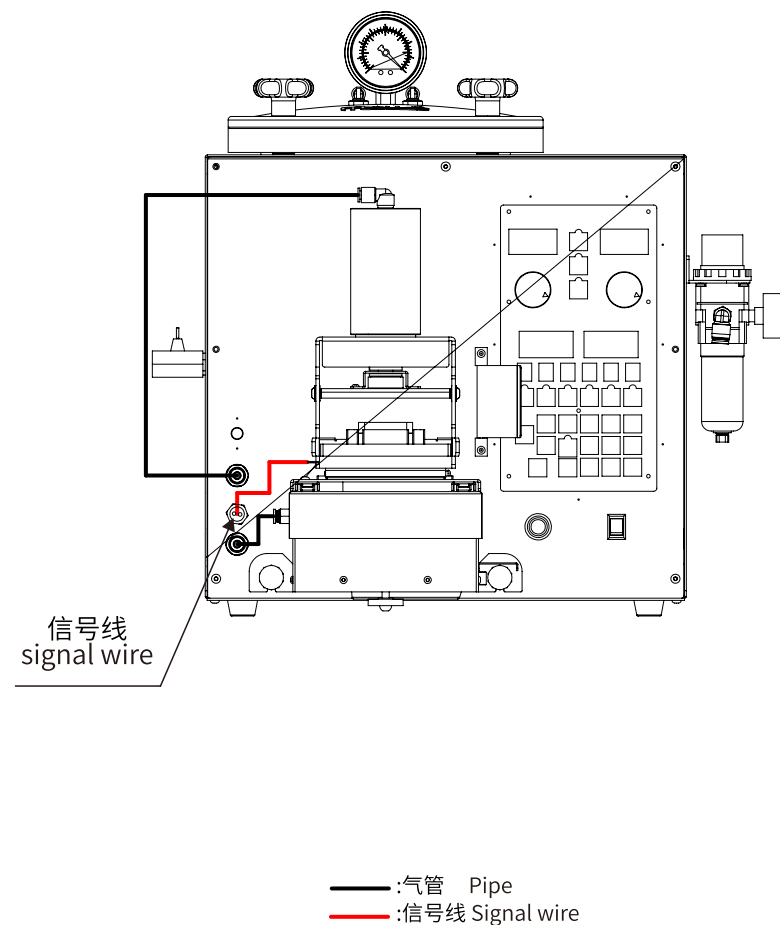

注蜡机箱背面气管、电源线连线示意图

Schematic diagram for the pipe and power wire connection on the back of the wax injector

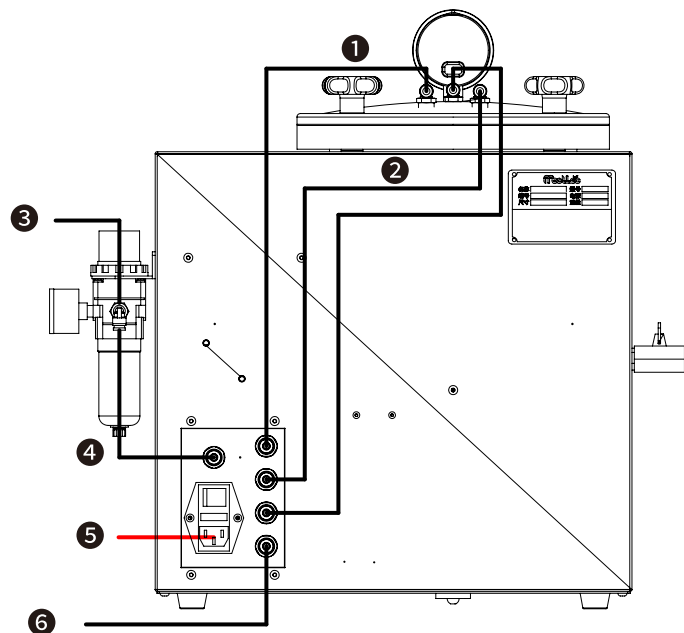

- ① 注蜡压力 Injecting pressure
- ② 蜡缸压力检测 Pressure detection for wax chamber
- ③ 压缩空气供给 0.4~0.7MPa Compressed air supply
- ④ 压缩空气输出 0.4MPa Compressed air output
- ⑤ 外部电源 AC220V±10% 50/60Hz External power supply
- ⑥ 至真空泵 For vacuum pump

— :气管 Pipe  
 — :电源线 Signal wire

### 三、操作面板介绍 Operation panel introduction

#### 1.操作面板示意图 Schematic diagram of operation panel

