

万动 VANSHAPE

14K LCD 3D PRINTER

M.PR.L-VAN70-WAX



专业3D打印机制造商
3d printer manufacturer

专业 敬业 合作 共赢

profession Dedication Cooperation Double-win

PREFACE

Notes: Every 3D printer goes through printing test before shipment. If there is some residue in the resin tank or some mild scratches on the platform after printing, it is a normal phenomenon and will not affect use.

Dear users

Thanks for choosing our products, your support and help.

Please read this manual (the Manual) before you use our products and conduct operation in accordance with the Manual.

Our after sales service team give you good-quality service. If you meet any problem in using our products, please kindly contact us in time.

In order to get a better experience of our products, you can acquire knowledge about our equipment from the Manual.

Please open the box of the product carefully. You can take out the Manual from the cotton on the top of the product. It will help you to know our equipment as soon as possible and finish the first printing experience.

NOTES

Tips: Please make you read the following tips.

Safe working environment

1. Please make sure the desktop where the printer works is clean
2. Keep the printer away from flammable gases, liquid and dust when it works. The temperature generated from the operation of the printer may react with dust, liquid and flammable gases to cause fire.
3. Children and untrained personnel can not operate this equipment alone.
4. When you operate the printer, please make sure that the platform is installed correctly without other objects to protect the LCD from being damaged.

Environment suitable for the equipment to work

1. Indoors temperature must be 15-30°C.
2. Humidity must be 20%-70%.
3. Please do not open the shading cover in the process of printing if it not necessary to avoid the light shines from outside will affect printing effect.

Requirements for placing the equipment

1. The equipment must be placed in a dry and well-ventilated environment. There must be space of at least 20cm from the left, right and back side of the printer, and at least 35cm from the front side.

Electrical safety

1. Please do not expose the equipment to the humidity or sunlight, humidity will increase the risk of electricity leakage while exposing to sunlight will shorten the service life of the plastic parts
2. To ensure safety, please use the power cord produced by manufacturers who run their business legally.
3. Please do not use the equipment in thunderstorms.
4. If you do not use the equipment for a long time, please turn off the equipment and plug out the power cord.

Personal operation safety

1. Please wear gloves when you use the photosensitive resin to prevent the it from contacting your skin.
2. When you operate the equipment, please wear a pair of rubber gloves and face mask.
3. Do not stare at the light source of the equipment.
4. Do operate the equipment after drinking and taking medicine.

Requirements for printing materials

1. Please use the materials provided or designated by manufacturers who run their business legally.
2. Low quality materials or materials that are not compatible with the equipment may affect printing success rate and experience.

Tips on using the Equipment

1. Do not leave the Equipment that is working for too long.
2. Do not refit the Equipment.
3. Do not do printing under strong sun
4. Operate the Equipment in a ventilated place.
5. Do not use the Equipment to engage in illegal and criminal activities.
6. Do not use the Equipment to make products that are used for storing food.
7. Do not use the Equipment to make electrical equipment.
8. Do not put the printed models into your mouth.
9. Do not remove the printed models violently.

Materials Storage Requirements

1. Please store the photosensitive resin in the dry environment out of children's reach. Please make sure the labels of the material bottles are in the visible direction. If the liquid is stored at low temperature, it needs to be shaken and the indoors temperature resumes to 20°C before use.
2. The photosensitive resin that is yet to be finished using must be placed without exposure to sunlight and main the environment cool and ventilated.
3. Printed models can be cleaned with alcohol after printing.

Final power of interpretation

If clients, without our consent, disassemble, assemble or refit the Equipment to cause any safety accident, we shall not be responsible for such accidents and reserve the final power of interpretation of the Manual.

LIST OF SPARE PARTS

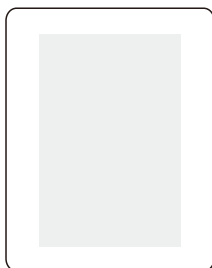

1* Nfep release film

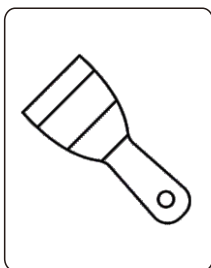

1* metal shovel



2* rubber gloves

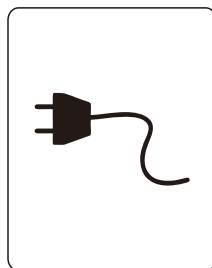

1* power line

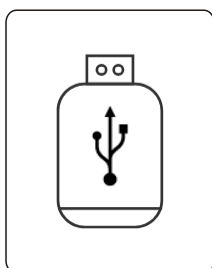

1* USB Stick

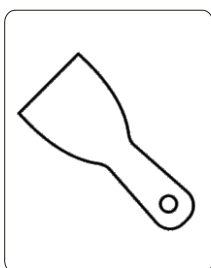

1* Plastic shovel

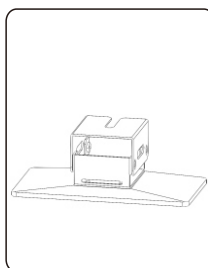

1 set of printing platform
and switch

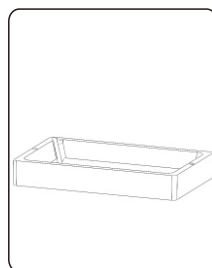

1* resin tank

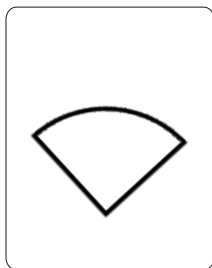

2* paper filters

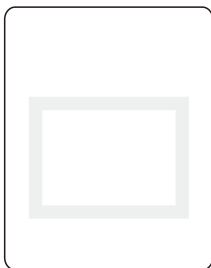

1* screen sticker



1* warranty card



1* product certificate

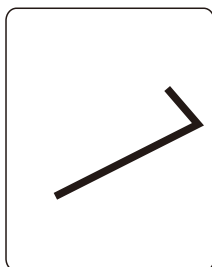

1* Allen key

MACHINE PARAMETERS

Model	M.PR.L-VAN70-WAX
Printing principle	Light curing shaping technology
printing size	223.78*126.98*250mm
printing precision	0.02mm
File format	.STL
Curing wavelength	405nm
Printing layer	0.025-0.1mm
Pixel	13320*5120pixel
Support function	Automatic generation through one key, editable
Compatible system	Window 7 or above
Printing speed	2-3 layer/s
Transmission	USB stick
Power input	100~240v AC50~60Hz
Power	150W
Slice software	ChiTu
Projection light source	LED
Material property	Photosensitive resin
XY resolution	16*24μm
Product size	337x467x795mm
Package size	mm
Net weight	48kg
Gross weight	58kg

FUNCTIONS OF THE OPERATION SCREEN

1. Document menu

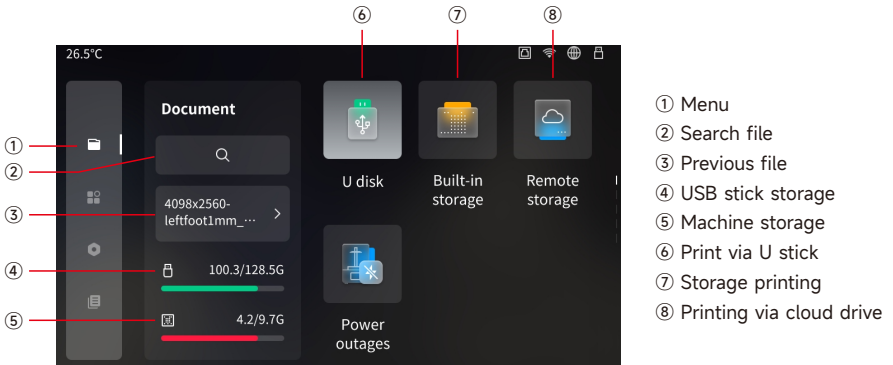

1.1 Printing through USB stick

Select the file that is to be printed as shown in the following Figure

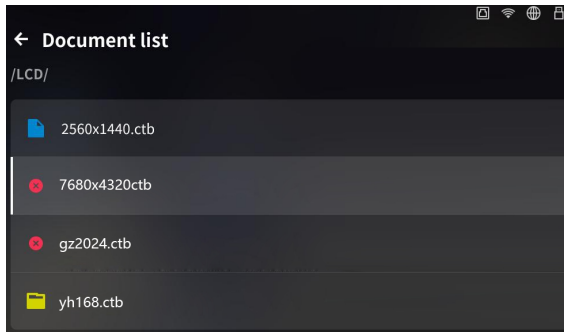

Choose a document and click "print" option as the Figure shows

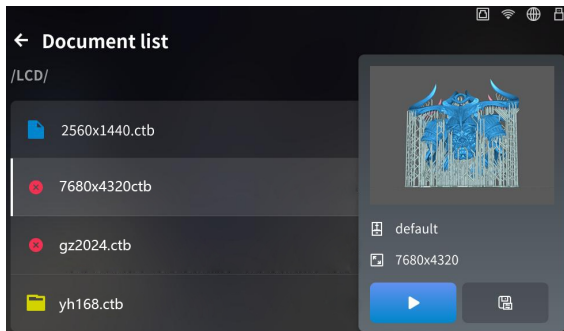

After clicking the “printing” option, you will enter the printing panel

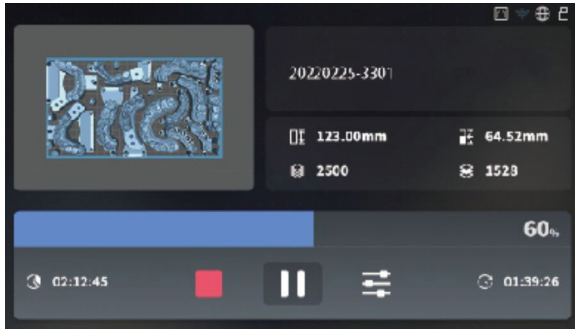

2. Feature menu

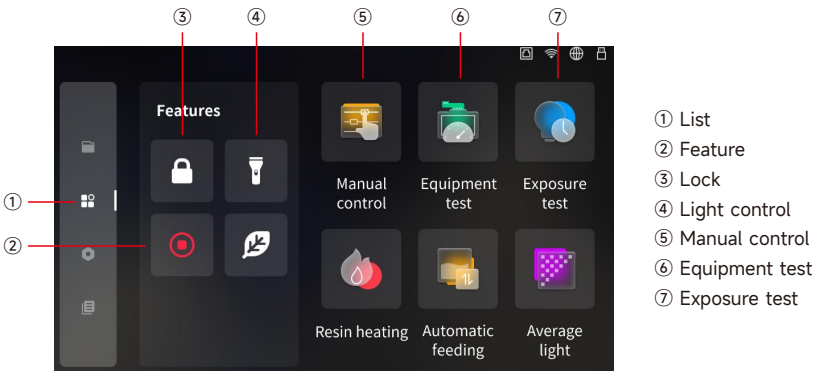

2.1 Click the feature menu (as shown in the upper figure). Click lock screen icon, the system enters lock screen state (as shown in the lower left figure) or the system will enter the state of locks screen protection (as shown in the lower right figure).

2.2 Click manual control to enter the interface as shown in the figure below. Whenever you enter the manual control interface, you need to click the button on the lower right corner so that you can operate "up" and "down". After resetting, slide the slider, then the printing platform can move. The buttons for each function are as shown in the figure below.

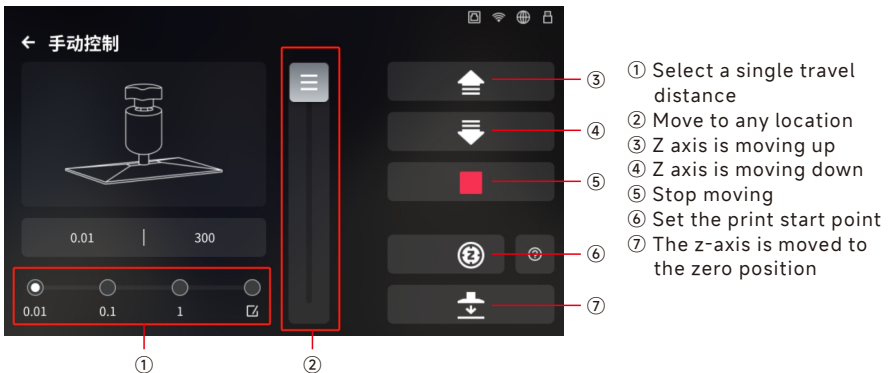

2.3 Equipment test. When you think that there is something wrong with some of the functions of this Equipment, you can enter the test interface on the Equipment to do a test (as shown in the following figure). This test can only apply to testing if some of the functions of the equipment are in good condition, but not to maintaining the functions. platform can move. The buttons for each function are as shown in the figure below.

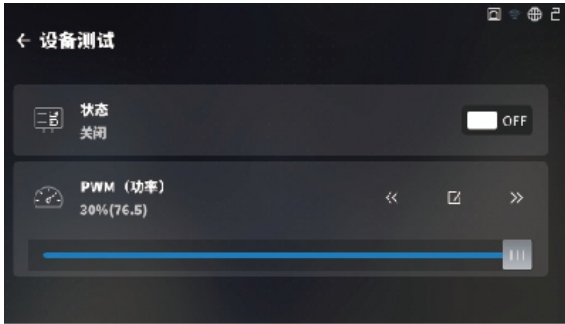

2.4 Exposure test is also used for testing the functions of the machine to determine if the machine has a fault or not. If exposure is in normal conditions after test, you need to find to other reasons.



For example, choose exposure test on the upper left corner, click "triangle" option on the lower right corner, enter the exposure interface (as shown in the figure below). If you need to pause exposure, pressure the "pause" option on the lower right corner.



SETTING

3.1 Click the Setting menu on the left, enter the panel (as shown in the following figure), There are WIFI setting, Internet setting, beeping sound, multiple languages setting and so on.

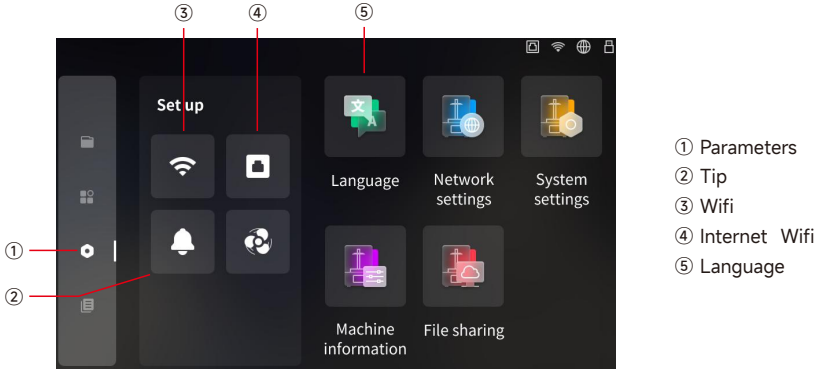

3.2 Click internet and WIFI setting, enter the panel (as shown in the following figure) for setting, including internet, name,IP etc. Attention: internet settings must be done within the same local area network.



When the machine can not recognize the internet, you can conduct manual setting (as shown in the following figure). After setting, click connect (as shown in the following figure).





3.4 Click “language” to enter the language setting panel. This machine has 12 languages for option. You can choose a language according to your need. After choosing, click the confirm option on the lower right corner (as shown).

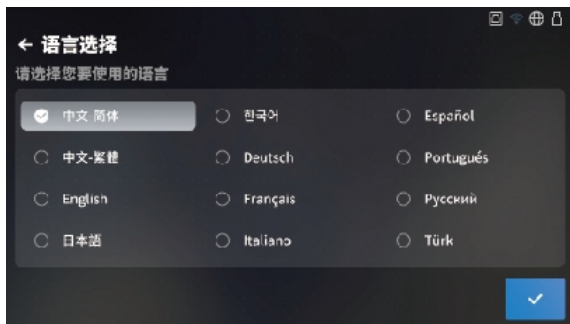

SLICE SOFTWARE INSTALLATION

ChiTubox software is in USB stick, you can install it on your computer. File path: USB stick-software installation package-ChiTubox 64Install_1.5.0. Double click the software file, make installation in the following order respectively (as shown).

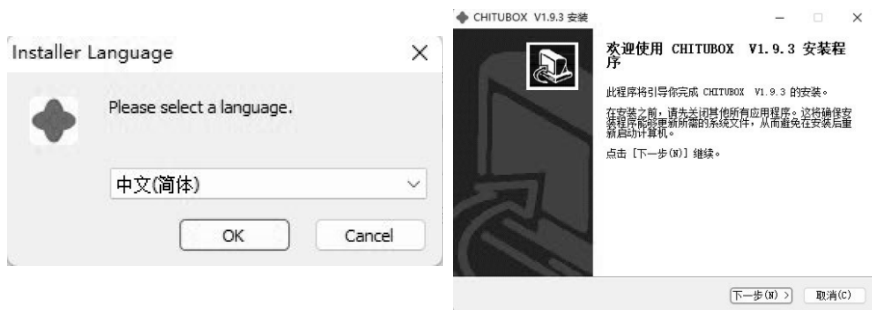

Click "OK", enter installation guide and click "Next" to start installation.

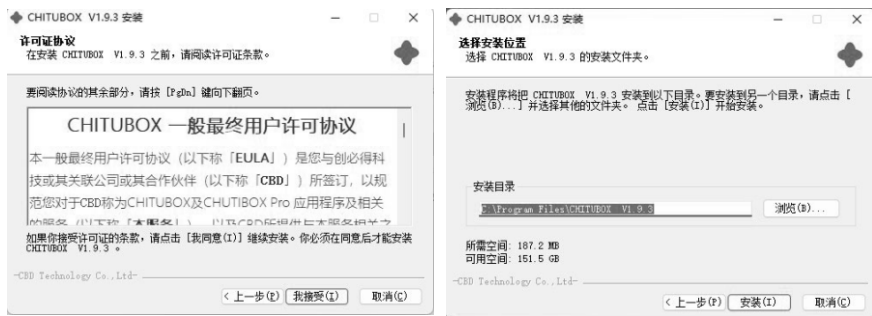

Click "I accept", then click "Install"



After installation is finished, click "done". Now you can operate the Chitubox

HOW TO USE SLICE SOFTWARE

After installing the software, this software will automatically operate (or double click the software icon). Click "file" on the right upper corner of the software interface, - click "open file" to export 3D model (stl file), Clicking model and pressing the mouse, you can change the view, angle, size and position of the model through the options on the left of the software interface.

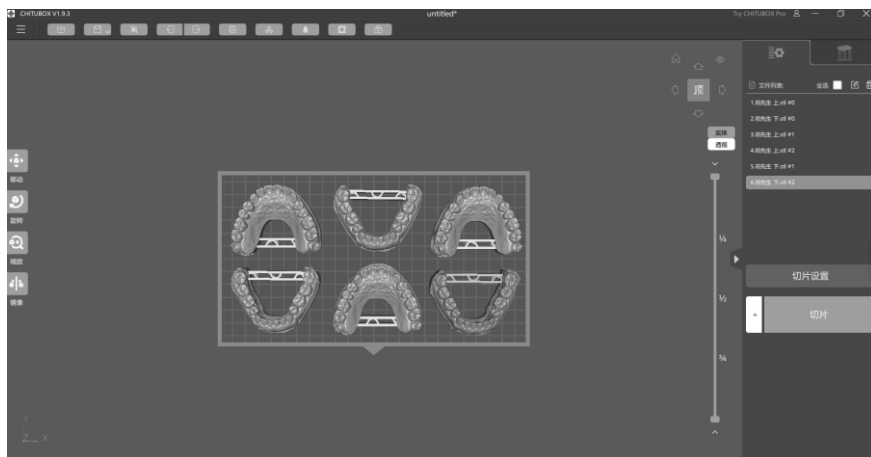

Other operations

1. Clicking the model by Left-clicking the mouse and hold, you can drag the mouse to move the model's position on the platform.
2. The view of the model can be zoomed in and out by rolling the the mouse roller.
3. Clicking the platform by right-clicking the mouse and hold, you can drag the mouse to rotate the view.
4. Click menu column, you will find a icon to switch languages between English and Chinese. Restart the software after you switch the languages , then the language is successfully switched.

SETTING PARAMETERS OF SLICE SOFTWARE

There are 3 settings which are "parameters", "support" and print size on the upper right corner of the software interface.

1. Set the parameters as shown in the following figures

Thickness of each layer: recommended value of 0.05mm, with a range of 0.01-0.2mm. The thicker the layer is, the longer exposure time of each layer is.

Normal exposure time: recommended time of 3s, with a range of 2-10s. Exposure time need to be set based on the thickness of each layer and complexity of details of your models. (the thicker, the layer is, the longer exposure time is).

Bottom exposure time: 50s, the longer the exposure time , the firmer the bottom layer sticks to the platform

Bottom layers : 3~6 layers

2. Setting support

The types of the supports can be set as thin, middle and thick.

Thin: the contact area between the support and model is small, making support easy to remove

Thick: the contact area between the support and model is large and firm. We suggest you set "middle"

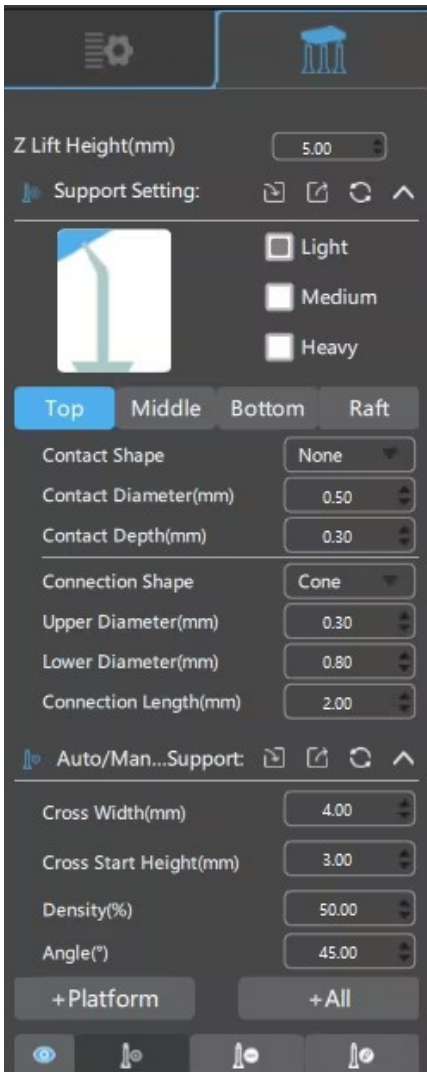

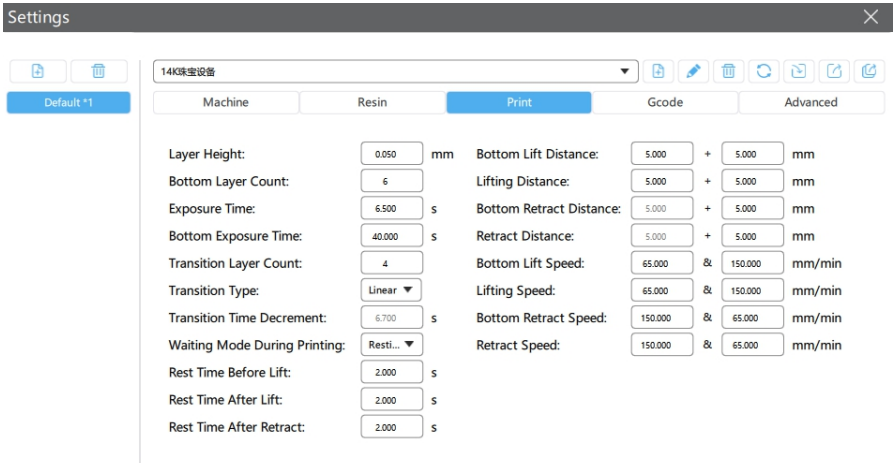

Interpretation: In addition, you can also import the parameters the manufacturer provides. Steps are as follow:

Click "Slice" in the pop-up dialog box, click "file" import stl file (This is just a reference only. Different parameters need to be imported for different machine model).

3. Save sliced file

After setting, click the "slice" icon on the lower right corner, save in the USB stick for starting slicing. Click "confirm" to finish slicing. You can also click "preview" to check path of the model and estimated printing time.

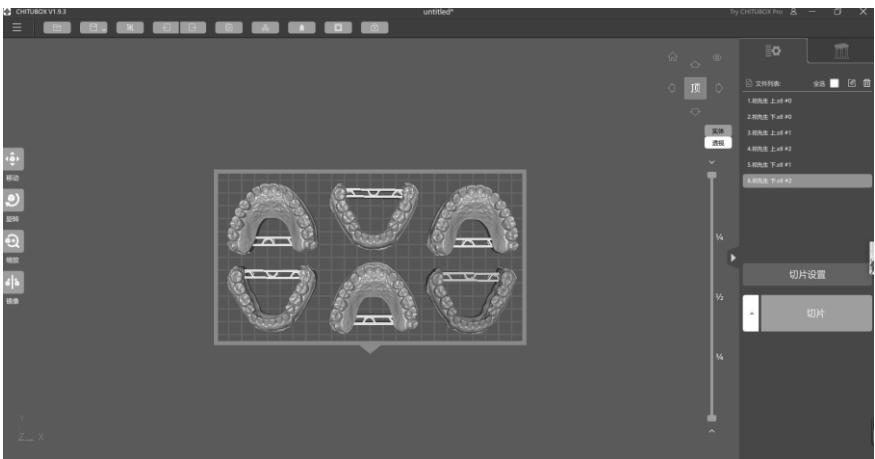

Please refer to the attached detailed user manual for the software

FIRST PRINTING

Note: To prevent failure in the first printing, please do the following checks:

1. If the exposure test is normal
2. If printing platform is parallel with
3. If the UV light is in normal condition

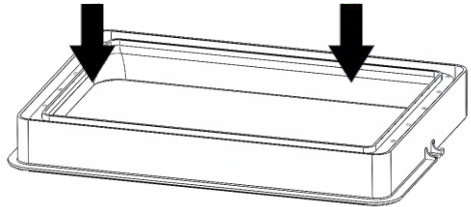
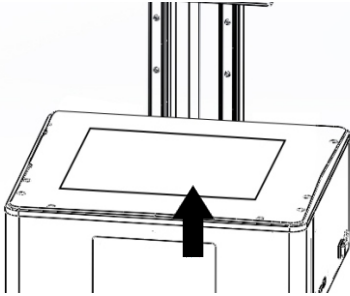

Please make sure that the bottom of the resin tank and the top of the printing screen are clean without any dirt or footprint.

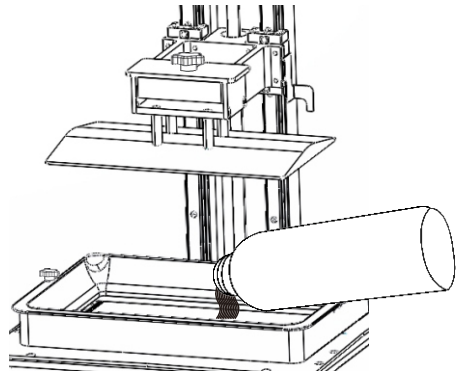
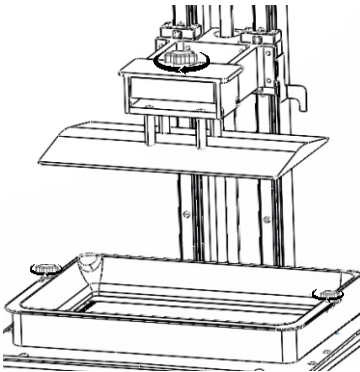

Tighten the screws clockwise on both right and left sides of the resin tank and the screws on the printing platform

After confirming the resin tank and printing platform are installed in the correct position, pour the resin into the resin tank slowly. The height of the resin in the resin tank must be below the marked line.



Click "print", enter U disk, find the file you need to print, then start printing.

Note: do not open the cover during the process of printing in case that your eyes will be injured.

POST-PRINTING TREATMENT

After printing, loosen the screw on the printing platform and take out the platform out of the machine. Remove the model with a shovel and wash it with alcohol containing 95% density.

In case of not curing thoroughly or printing not successfully, there may be some solid residue left in the resin tank. We suggest that you filter the resin in the tank with a tulip, throw the residue away if any, and store the resin in the resin bottle. Otherwise, when you level the platform and do printing next time, the printing platform may damage the LCD as it moves down.

The residue in the tank or on the platform may be cleaned with a piece of paper.

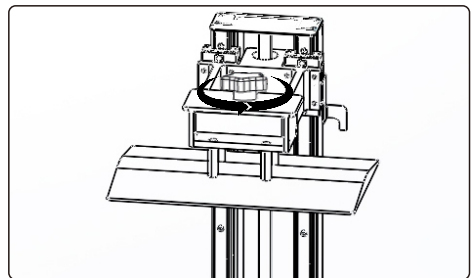

When printing is finished, the display will show printing done, click "confirm" and open the shading cover.

Loosen the screws on the platform and remove the platform

Note: When removing the printed model, do not damage the release film or the LCD screen.

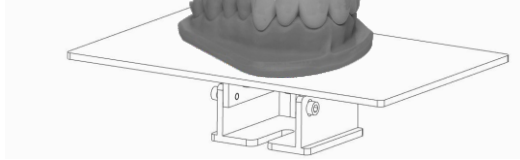

Remove the model with a shovel, and put it in an equipment containing water.

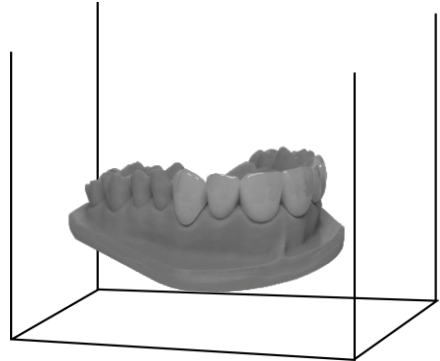
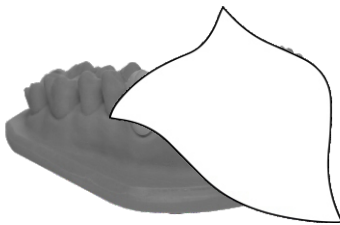
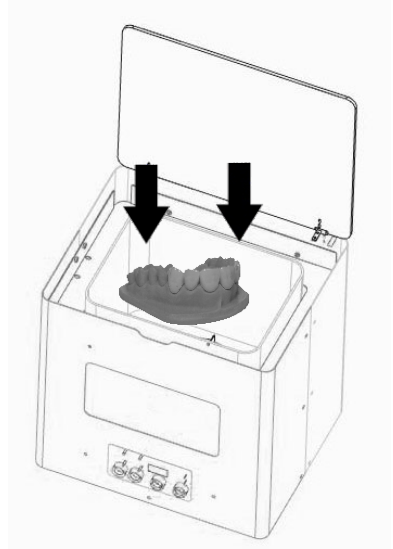

After cleaning, dry the model with a dust-free cloth or air gun to air-dry it, then put it in a curing case for curing again

Note: Be careful when you install or remove the platform in case that the platform will fall down and damage the LCD

1. If the machine continuously works for relatively long time, observing printing at regular time is necessary to prevent accidents. When the model is
2. Please keep the working environment clean and dirt-free
3. If you are a beginner, please confirm the installation and mind the gap between the platform and LCD.

REPLACE THE RESIN TANK

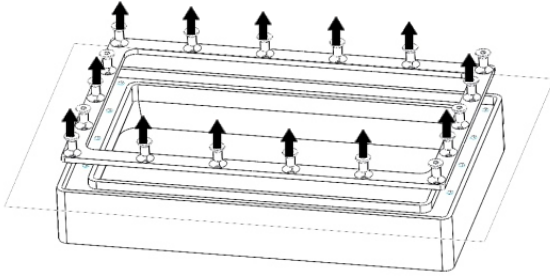

1. Remove the screws beneath the bottom of the tank, remove the screws fixing the release film and replace the old release film with a new one.

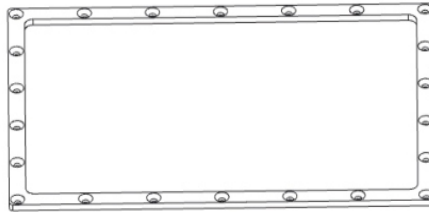

2. Align the release film with the screw holes, clamp it between two fixed frames, and tighten the screws.

Attention: The fixed frame has both sides, and the correct installation can be determined through the screw hole position.

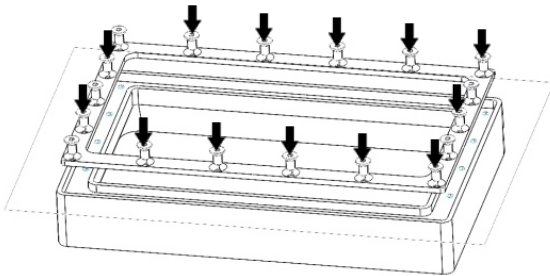

Install the fixed frame back to the bottom of the resin tank, tighten the screws to tighten the release film. Then pour water or resin into the resin tank to check for any leakage. If any leakage is found, the release film needs to be reinstalled.

Attention: The above operation protects the release film from damage and dirt.

WARRANTY

Dear Customers:

Thanks for choosing our products. You will enjoy one-year warranty after-sales service. Certain maintenance charges generated from the damage caused by man-made errors will be for the customer's account. Please keep the machine properly.

WARRANTY FOR THE PRODUCT

1. The warranty period of this product is 1 year. Consumables, LCD and release film are not covered in one-year warranty.
2. Certain charges of materials or service will be charged under one of the following conditions.
 - a. Fault or damage caused by improper use
 - b. Faults caused by man-made damages
 - c. Using other materials or not using designated materials
 - d. Personnel beyond our companies disassemble the machine or the warranty period expires
3. Relevant fees will be borne by users under one of the following circumstances
 - a. Faults or damages caused by natural disasters or Force Majeure
 - b. Damaged caused by incorrect operation or disassembly
 - C. Damages caused by man-made errors.

The pictures of products, spare parts, user interface are for reference only. Due to the update and upgrade of the products, real items may differs slightly from the pictures.

万协 VANSHAPE

广州市万协科技有限公司

Guangzhou Vanshape Technology Co.,Ltd

地址:广东省广州市番禺区沙湾镇福涌牛眠岗工业区一街10号

Add.:No.10,FirstStreet,NiumiangangIndustrialPark,Fuchong,Shawan
Town,PanyuDistrict,GuangzhouCity,Guangdongprovince,China

电话/Tel: +86-20-3483-3255传真/Fax: +86-20-3483-3255

邮箱/Email: export@vanshape.com

网址/Web: www.vanshape.com